

CCA5 & CCA7 Extractors

Installation, Use and Maintenance

Important

The CDA Group Ltd cannot be held responsible for injuries or losses caused by incorrect use or installation of this product. Please note that CDA reserve the right to invalidate the guarantee supplied with this product following incorrect installation or misuse of the appliance or use in a commercial environment.

This appliance is not designed to be used by people (including children) with reduced physical, sensorial or mental capacity, or who lack experience or knowledge about it, unless they have had supervision or instructions on how to use the appliance by someone who is responsible for their safety.

Under no circumstances should any external covers be removed for servicing or maintenance except by suitably qualified personnel.

Appliance information:

Please enter the details on the appliance rating plate below for reference, to assist CDA Customer Care in the event of a fault with your appliance and to register your appliance for guarantee purposes.

Appliance Model	
-----------------	--

Serial Number	
---------------	--

EU Declarations of Conformity:

This appliance has been manufactured to the strictest standards and complies with all applicable legislation, including Gas safety, Electrical safety (LVD) and Electromagnetic interference compatibility (EMC).

IMPORTANT INFORMATION FOR CORRECT DISPOSAL OF THE PRODUCT IN ACCORDANCE WITH EU DIRECTIVE 2012/19/EU.

At the end of its working life, the product must be taken to a special local authority waste collection centre or to a dealer providing appliance recycling services.

Disposing of a household appliance separately avoids possible negative consequences for the environment and health. It also enables the constituent materials to be recovered, saving both energy and resources. As a reminder of the need to dispose of household appliances separately, the product is marked with a crossed-out wheeled dustbin.



Please note:

- Under no circumstances should the extractor be connected to any gas ventilation system, flue system or hot air ducting system.
- Do not vent the extractor into an attic or loft space.
- Only house the extractor in rooms with adequate ventilation. Remember that the extractor is powerful and whatever air is extracted needs to be replaced.
- Do not tile the extractor in. It should be removable for service or maintenance.
- Do not use silicone sealant to secure the hood to the wall.
- You must be able to isolate the extractor from the mains electrical supply after installation.
- This extractor has been designed to be used in a room with a volume of less than 36m³.
- Steam cleaners must not be used when cleaning this appliance.
- The performance of your extractor will vary depending on a number of factors. These include: type of extraction, length of ducting, room volume, ventilation available and cleanliness of the filters.

Using your Extractor

For best performance, you should switch on the extractor 15 minutes before starting to cook and leave it to run for approximately 15 minutes after the end of cooking.

A - Light switch

B - Power indicator light

C - Power switch

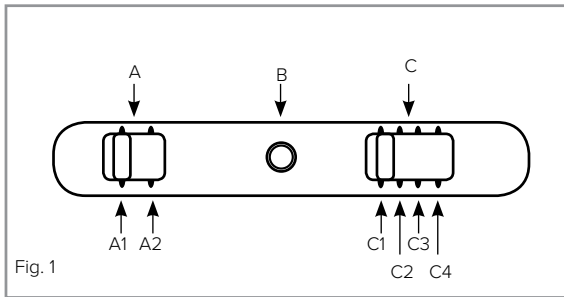

To switch the extractor light on or off

- Slide the light switch to position A1 for off, or A2 for on.

To switch on the extractor, or change the motor speed

- Slide the power switch to the position required dependent on the speed you require.

To switch the extractor off

- Slide the power switch to position C1 for off.

Care and Maintenance

IMPORTANT: DO NOT PERFORM MAINTENANCE OR CLEANING OF THE EXTRACTOR WITHOUT FIRST SWITCHING OFF THE ELECTRICITY SUPPLY.

Cleaning

You should use a non-abrasive cleaner. Any abrasive cleaner (including Cif) will scratch the surface and could erase the control panel markings.

You can clean you extractor effectively by simply using a dilute solution of water and mild detergent and drying to a shine with a clean cloth, for example the CDA E-Cloth.

Cleaning the grease filter

The grease filter should be kept clean to minimize the risk of fire. At least once a month you should remove and clean the grease filter with hot soapy water.

To remove the grease filter, follow the steps below:

1. Unfasten the sliding brackets on either side of the cover panel and the cover panel will hinge open.
2. Remove the filter retaining wires from the cover panel.
3. Remove the grease filter and wash by hand in a lukewarm solution of

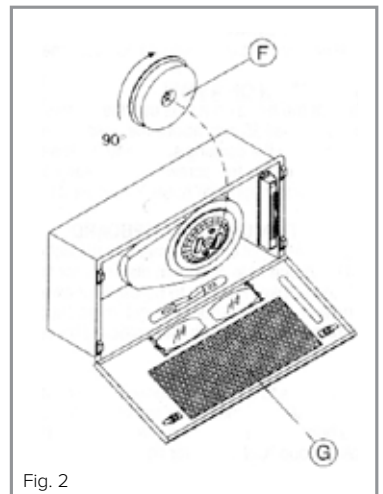

water and mild detergent. Once clean, squeeze the grease filter but **DO NOT** wring it out. Clean the filter holder using a dilute solution of water and mild detergent or with a damp cloth. Allow the grease filter to dry completely before reassembling the extractor.

4. Replace the grill panel and refasten the sliding brackets.
5. Replace the grease filter in the cover panel and reattach the filter retaining wires.

Please note:

The extractor must not be used without the grease filter in place.

Changing the charcoal filter

To ensure best performance of your extractor, you should replace the charcoal filters every four to six months, depending on use. Please note the charcoal filter cannot be washed. To attach a new charcoal filter, follow the steps below.

1. Unfasten the sliding brackets on either side of the cover panel and the cover panel will hinge open.
2. Place the charcoal filter on the centre of the motor support, and once firmly located turn the charcoal filter clockwise 90° until you hear a click which locks the charcoal filter into position.

Replace the cover panel and refasten the sliding brackets.

Changing the light

IMPORTANT: DO NOT PERFORM MAINTENANCE OR CLEANING OF THE EXTRACTOR WITHOUT FIRST SWITCHING OFF THE ELECTRICITY SUPPLY.

DO NOT CHANGE THE LIGHT BULB IMMEDIATELY AFTER USE AS THE BULB WILL BE HOT. ALLOW IT TO COOL BEFORE REMOVING IT.

1. Unfasten the sliding brackets on either side of the cover panel and the cover panel will hinge open.
2. Remove the faulty light bulb and replace with a light bulb no more powerful than that specified on the rating plate.
3. Replace the cover panel and refasten the sliding brackets.

Do not touch bulbs or adjacent areas during or straight after prolonged use of the lights.

The light is designed for use during cooking and not for general room illumination. Extended use of the light can reduce the lifespan of the bulb.

Bulb replacement is not covered by the guarantee.

Only use bulbs recommended for your extractor. Do not fit bulbs of a higher power rating. Bulbs of a lower power rating may be adequate for use, generally last longer, and use less energy.

Spare bulbs are available from CDA Customer Care or from your local DIY shop.

Mains Electricity Connection

THIS APPLIANCE MUST BE CONNECTED TO THE MAINS SUPPLY BY A COMPETENT PERSON, USING FIXED WIRING VIA A DOUBLE POLE SWITCHED FUSED SPUR OUTLET AND PROTECTED BY A 3A FUSE.

We recommend that the appliance is connected by a qualified electrician, who is a member of the N.I.C.E.I.C. and who will comply with the I.E.E. and local regulations.

The wires in the mains lead of this appliance are coloured in accordance with the following code:

BLUE = NEUTRAL, BROWN = LIVE.

As the colours of the wires in the mains lead for the appliance may not correspond with the coloured markings identifying the terminals connecting to the fused spur, proceed as follows:

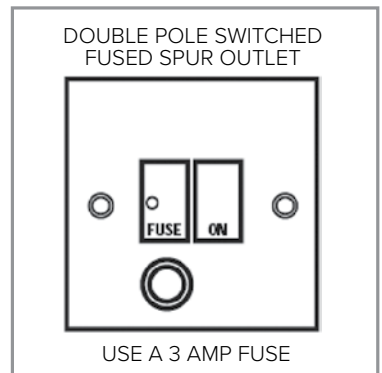

-
- The wire which is coloured blue must be connected to the terminal marked N (Neutral), or coloured black.
 - The wire which is coloured brown must be connected to the terminal marked L (Live), or coloured red.

NOTE: USE A 3A FUSE

Assembly and electrical connection should be carried out by competent personnel.

When installing this product we recommend you seek the help of another individual.

IMPORTANT: THIS APPLIANCE IS A CLASS II APPLIANCE (DOUBLE INSULATED) AND IS NOT INTENDED TO BE EARTHED. DO NOT FIT AN EARTH LEAD TO THIS EXTRACTOR.

Do not mount the isolation switch behind the chimney section. It is a requirement that you must be able to isolate the extractor from the mains electrical supply after installation.

This appliance is intended to be connected to the mains electrical supply by means of an isolation switch and fused spur and is intended to be protected by a 3A fuse. The use of a 13A fuse can cause damage to the internal wiring in the event of a fault, and may also invalidate the warranty.

Electrical Information

Mains electrical voltage: 230 – 240Vac.

Total rated power consumption CCA5: 128W.

Total rated power consumption CCA7: 256W.

Troubleshooting

Please note:

Your extractor is equipped with a motor protection device that will switch off the motor to prevent damage from overheating. This may happen during cooking when most or all of the zones/burners are being used simultaneously.

This is normal, and the extractor will work again once the motor has cooled sufficiently.

If your extractor is not working:

1. Check that the mains supply has not been switched off.
2. Check that the fuse in the spur has not blown.

Contact CDA Customer Care

A : Customer Care Department, The CDA Group Ltd, Harby Road,
Langar, Nottinghamshire, NG13 9HY

T : 01949 862 012

F : 01949 862 003

E : customer.care@cda.eu

W : www.cda.eu

Installation

When the extractor is to be installed above an electric hob, the minimum distance between the hob and extractor must exceed 600mm (650mm is recommended).

When the extractor is to be installed above a gas hob, the minimum distance between the hob and extractor must exceed 700mm (750mm is recommended).

If the instructions provided with your gas hob state that the required distance between the hob and extractor must be greater than 700mm, then that is the distance that should be observed; this is a legal requirement and may lead to your hob being disconnected from the gas supply and the installation being reported to RIDDOR (The height should be measured from the top of the burners).

IN THE ABSENCE OF ANY INSTRUCTIONS SUPPLIED WITH THE GAS HOB, THE MINIMUM DISTANCE BETWEEN THE HOB AND EXTRACTOR MUST BE AT LEAST 760mm.

The width of any hob must not be greater than the width of the extractor installed above it.

Mounting your Extractor

The extractor can be mounted in one of two ways:

1. Mark out the dimensions of the cut-out based on your hood; the dimensions required are as follows: -

Version	Cut-out Width	Cut-out Depth
CCA5	495	257
CCA7	695	257

2. Hold the extractor in the housing and secure to the canopy using 4 wood screws, located in the corner of the extractor, as shown as C in figure 3. We recommend that you seek the help of another individual when carrying out this task.

3. Connect the exhaust pipe to the duct adapter (B in figure 2) and locate on the extractor, as indicated. We recommend the use of 120mm (5") ducting, although 100mm can be used with the use of a 120-100mm converter; Note that this will affect performance.

Figure 3 shows how the extractor should be vented.

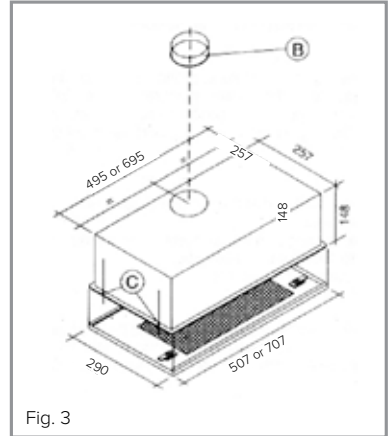

Fig. 3

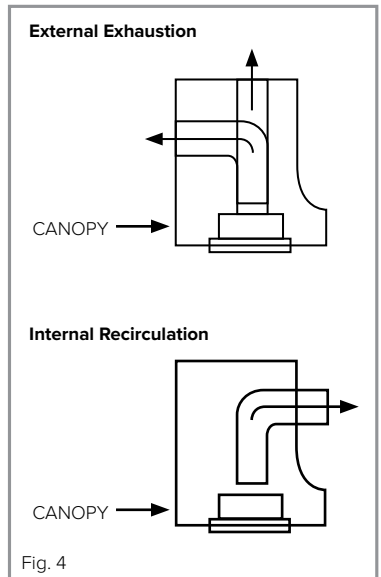

Fig. 4

Energy Efficiency Information				
Attribute	Symbol	Value		Units
Model Identification		CCA5	CCA7	
Annual Energy Consumption	AEC_{Hood}	69.5	167.2	kWh
Time increase factor	f	1.8	1.8	
Fluid Dynamic Efficiency	FDE_{Hood}	5.1 (F)	6.2 (F)	
Energy Efficiency Index	EEL_{Hood}	97.3 (D)	109.1 (E)	
Measured airflow at Best Efficiency Point	Q_{BEP}	108	205.3	m^3/h
Measured Pressure at Best Efficiency Point	P_{BEP}	125	210	Pa
Maximum airflow	Q_{MAX}	195.0	313.0	m^3/h
Measured electric power at Best Efficiency Point	W_{BEP}	74	194.8	W
Nominal lighting power	WL	28.0	56.0	W
Average illumination of the lighting system on the cooking surface	E_{Middle}	55.0	95.0	Lux
Measured power consumption in standby	P_S	NA	NA	W
Measured power consumption off mode	P_O	NA	NA	W
Sound power level	L_{WA}	65.0	73.0	dBA
Grease Filter Efficiency	GFE_{Hood}	81 (C)	66 (D)	%
Lamp efficiency	LE_{Hood}	2(G)	1.7(G)	%

